

WARRANTY

3

YEARS OR
100,000KM
whichever comes first

POWERFUL YET ECONOMICAL

ALL-NEW 3.0L 4X4 SINGLE CAB



ISUZU
D-MAX
SUPER COMMONRAIL



More efficient. More economical.

The latest engine from Isuzu is extremely fuel efficient, as was dramatically proven in the Dura-Miles Challenge from Bangkok to KL where the D-Max covered an amazing 1501km with less than one full tank. Plus you save even more with low maintenance and parts costs.

The powerful 136ps engine.

The latest Direct Injection Electronic Super Commonrail system enhances combustion to max potential, unleashing an awesome output of 136ps power. Achieves a maximum torque from 1200rpm, giving you a powerful drive even while carrying heavy loads.

Touch-on-the-Fly



The first with convenient one-button switching from 2-wheel drive to 4-wheel drive and vice versa at speeds of up to 100km/h.

Timing Gear & Chain

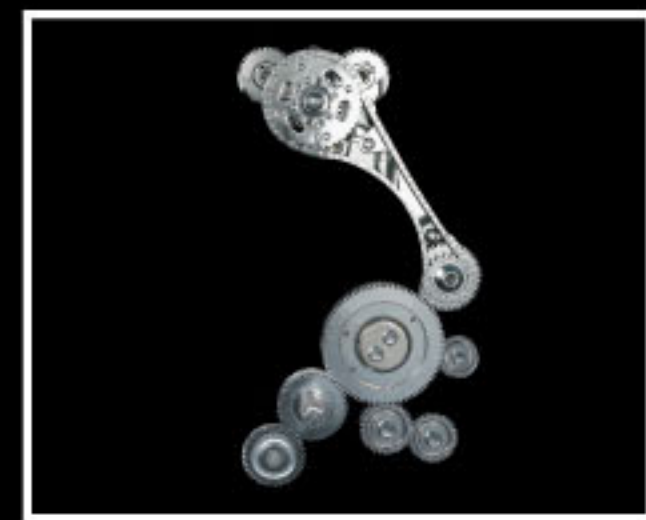

Compared to the ordinary timing belt, the timing gear & chain is definitely longer lasting. It keeps the motion going without the possibility of snapping.

Reinforced Chassis

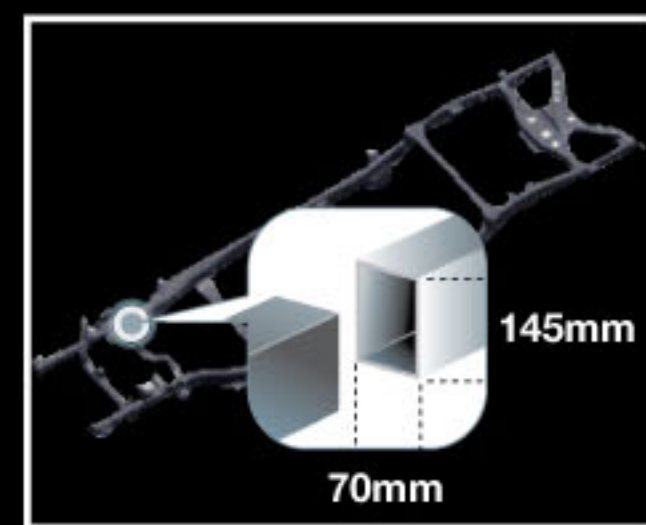

High-performance frame with larger side-members further increases safety and durability. Specially designed rear chassis cross member minimises torsional distortion.



PERFORMANCE CURVE

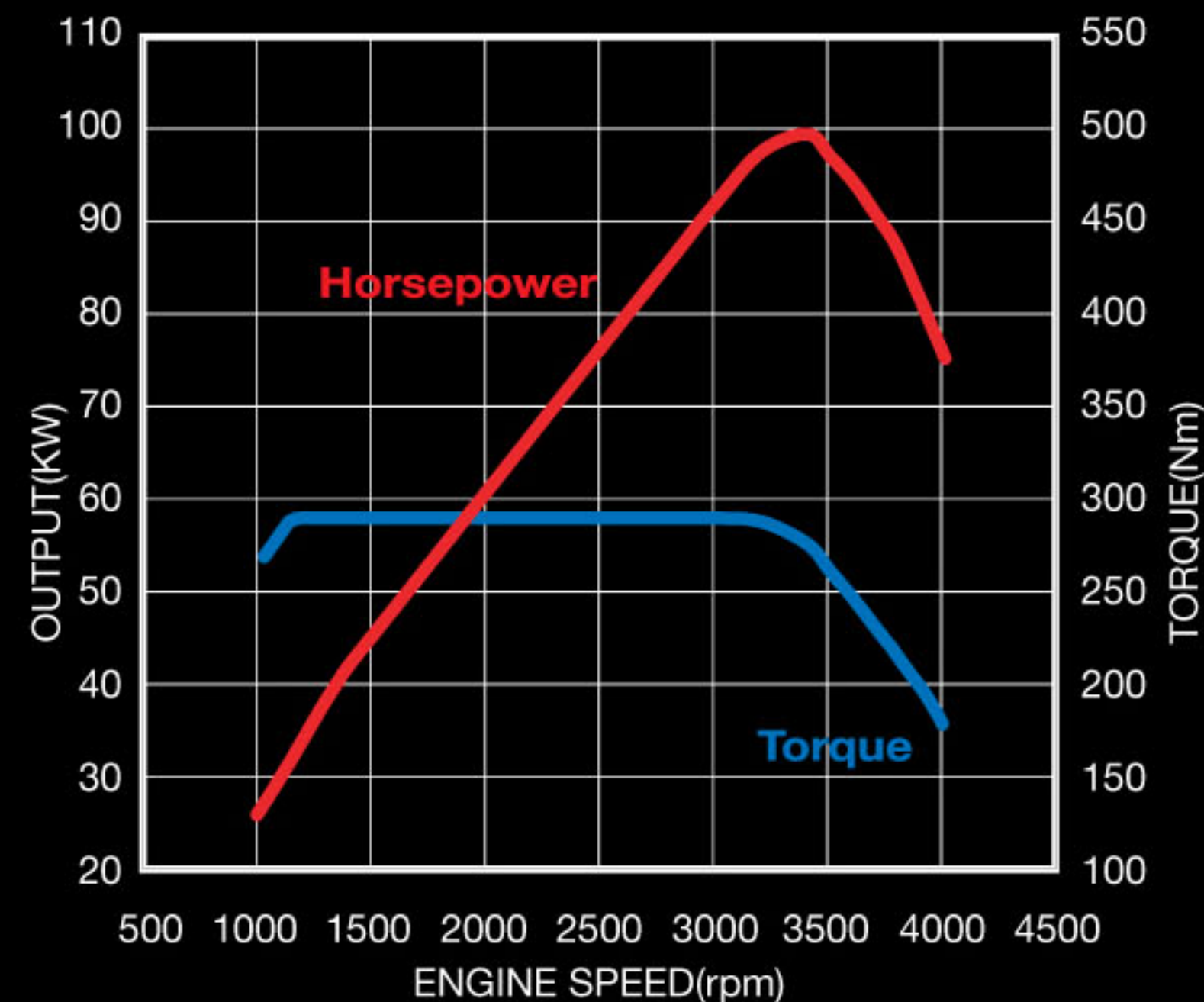

DIMENSIONS (unit : mm)

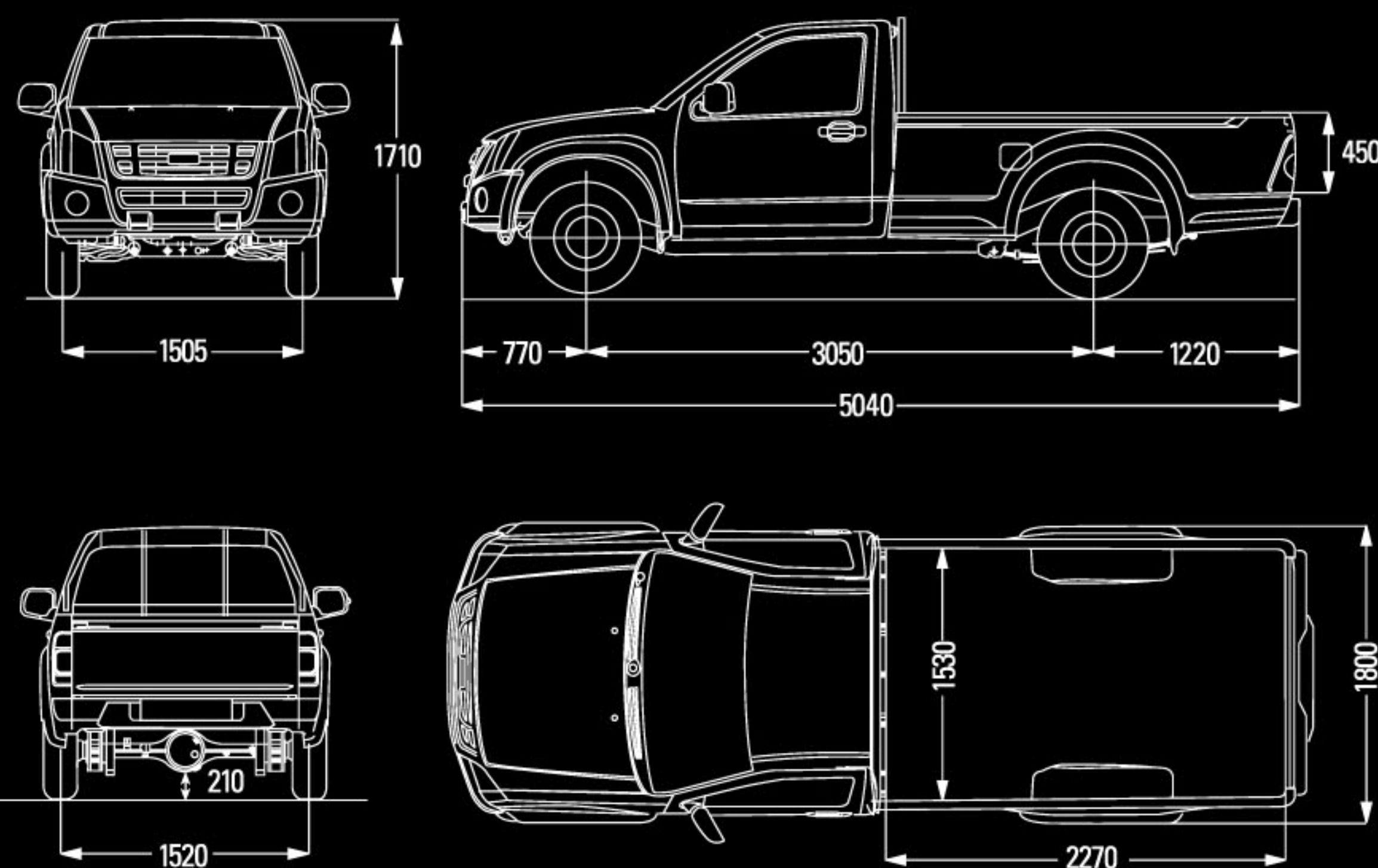

SPECIFICATIONS

3.0L Ddi i-TEQ Super Commonrail 4x4 MT

ENGINE	
Model	4JJ1-TC
Type	In-line 4-Cylinder Turbo Intercooler Diesel DOHC 16V
Displacement (cc)	2,999cc
Maximum Output (kW (PS) @ rpm) [ISO NET]	100 (136) @ 3400
Maximum Torque (Nm (kgm) @ rpm) [ISO NET]	280 (28.6) @ 1200 - 3400
Fuel System	Direct Injection Electronic Commonrail
Transmission	5-speed manual
SUSPENSION & BRAKES	
Suspension Front	Independent Double Wishbone with Torsion Bar Springs & Stabilizer
Rear	Semi-Elliptical Leaf Springs
Shock Absorber	All Wheel Double Action Telescopic Gas
Brakes Front	Ventilated Disc with 2-Pot Calipers
Rear	Leading-and-Trailing Drums
STEERING	
Steering System	Rack & Pinion Power Steering System
Min. Turning Radius (m)	6.2
TYRES & WHEELS	
Tyres	225/75R15C
Wheels	15 x 6.5JJ Steel
WEIGHT & CAPACITIES	
Gross Vehicle Weight (kg)	2750
Seating Capacity	3 persons
Fuel Tank Capacity (L)	76
SAFETY FEATURES	
Body Construction	Reinforced Cabin with Front & Rear Safety Crushable Zones
Side Door Impact Beams	Equipped
Collapsible Steering Column	Equipped
Limited Slip Differential (LSD)	Equipped
Wheel Stopper	Equipped
Seat Belts	Adjustable 3-Point ELR & 2-Point for Middle Occupant

Dealer Information



ISUZU MALAYSIA SDN BHD (664946-H) 501D, LEVEL 5, TOWER D, UPTOWN 5, NO.5, JALAN SS21/39, DAMANSARA UPTOWN, 47400 PETALING JAYA, SELANGOR DARUL EHSAN.
GENERAL LINE: 03-7723 9777 FAX: 03-7723 9779 HOTLINE: 1-300-88-1133

*Specifications may vary.